

Open-area Smoke Imaging Detection (EF-OSID) by ICAM is a new innovation in projected beam smoke detection technology. By using advanced dual wavelength projected beam and optical array imaging technology for early warning smoke detection, EF-OSID provides a low-cost, reliable and easy-to-install solution that overcomes typical beam detection issues such as false alarm incidents and alignment difficulties.

Unique Detection Technology

The EF-OSID system measures the level of smoke entering beams of light projected over an area of protection. Up to seven Emitters each project a wide-angled beam toward a single Imager. Two innovations in smoke detection technology have been developed and used for the revolutionary EF-OSID smoke detector.

Dual Wavelength Particle Detection

The beam projected from each Emitter contains a unique sequence of ultraviolet (UV) and infrared (IR) pulses that are synchronised with the Imager and enable the rejection of any unwanted light sources.

By using two wavelengths of light to detect particles, the system is able to distinguish between particle sizes. The shorter UV wavelength interacts strongly with both small and large particles while the longer IR wavelength is affected only by larger particles. Dual wavelength path loss measurements therefore enable the detector to provide repeatable absolute smoke obscuration values, while rejecting the presence of dust particles or solid intruding objects.

Optical Imaging with Photo-cell Arrays

An optical imaging array in the Imager provides the detector with a wider viewing angle to locate and capture images. Consequently, the system can tolerate a much less precise installation and can compensate for the drift caused by natural shifts in the building structure.

Optical filtering, high-speed image acquisition and intelligent software algorithms also enable the Imager to process the image and provide new levels in stability and sensitivity while providing greater immunity to high level lighting variability.

Operation

Status information (Fire Alarm, Fault and Power) is communicated through the Imager via Status LEDs, dedicated Trouble and Alarm relays, and Remote Indicator interface. Specific (Fault) conditions are identified through different activation sequences of the Trouble LED.

An internal heating option is also provided to prevent condensation in the optical surfaces, and a reset input enables an external signal to reset the device.



Features

- Maximum detection range up to 150 m (492 ft)
- Status LEDs for Fire, Trouble and Power
- High false alarm immunity
- Dust and intrusive solid object rejection
- Easy alignment with large adjustment and viewing angles
- High alignment tolerances
- Simple DIP switch configuration
- Dual wavelength LED-based smoke detection
- Limited maintenance requirements
- Conventional alarm interface for straightforward fire system integration
- Configurable alarm thresholds

Listings/Approvals

- Major Agency Approvals pending
- UL/ULC

Simple Installation and Maintenance

The detector system consists of up to seven Emitters, for the 45° and 90° units, placed along the perimeter of the protected area, and an Imager mounted opposite. Each component can be mounted directly to the surface or can be secured via supplied mounting brackets.

On the Imager, a termination card provides all field wiring terminals, and DIP switches enable the user to configure the detector for particular applications.

Alignment of the Emitter is simply achieved by using a laser alignment tool to rotate the optical spheres until the laser beam from the alignment tool is within proximity to the Imager.

The Imager field of view (FOV) can be aligned in a similar way to encompass all Emitters. A Fault will be indicated when a Emitter is missing from the field of view.

The EF-OSID system is highly tolerant to dust and dirt and requires little maintenance in practice. Preventative maintenance is limited to occasionally cleaning the optical faces of the components.

Configuration Options

EF-OSID systems may be configured to suit a range of detection spaces by selecting the number of Emitters and type of Imager. Each type of Imager differs by the lens used in the unit, which determines the field of view and range of the system.

| Imagers | | Emitters | |
|---------------|----------|-------------------------|----------------|
| Field of View | | Maximum Detection Range | |
| Horizontal | Vertical | Standard Power | High Power |
| 10° | 5° | 150 m (492 ft) | - |
| 40° | 20° | 60 m (197 ft) | 120 m (394 ft) |
| 80° | 40° | 34 m (112 ft) | 68 m (223 ft) |

| | |
|----------------------------------|--|
| Supply Voltage | 15 to 32 VDC (24 VDC nominal) |
| Imager Power Consumption | Nominal at 24 VDC: 80 mW (1 Emitter), 400 mW (7 Emitters) |
| | Maximum at 32 VDC: 105 mW (1 Emitter) 530 mW (7 Emitters) |
| Emitter Power Consumption | Loop/Circuit Powered: 6 mW max. (200 µA at 32 VDC) |
| | Built-in Lithium Battery: 5 year-plus lifetime battery expectancy |
| Field Wiring | 12-way screw terminal Maximum: 2.5 mm ² (13 AWG) |
| Alarm Settings | Alarm levels: Low, Medium, High |
| Adjustment Angle | ±60° (horizontal) ±15° (vertical) |
| Dimensions (WHD) | Emitter / Imager: 198 mm x 130 mm x 94 mm (7.80 in. x 5.12 in. x 3.74 in.) |
| Operating Conditions | Temperature: -10 to 55 °C (14 to 131 °F) |
| | Humidity: 10 to 95% RH (non-condensing) |
| | Please consult your Xtralis office for operation outside these parameters. |
| IP Rating | IP 44 for Electronics IP 66 for Optics Enclosure |
| Emitter LED Wavelengths | IR: 850 nm (typical) UV: 405 nm (typical) |
| Status LEDs | Fire Alarm (Red) Trouble / Power (Bi-color Yellow / Green) |

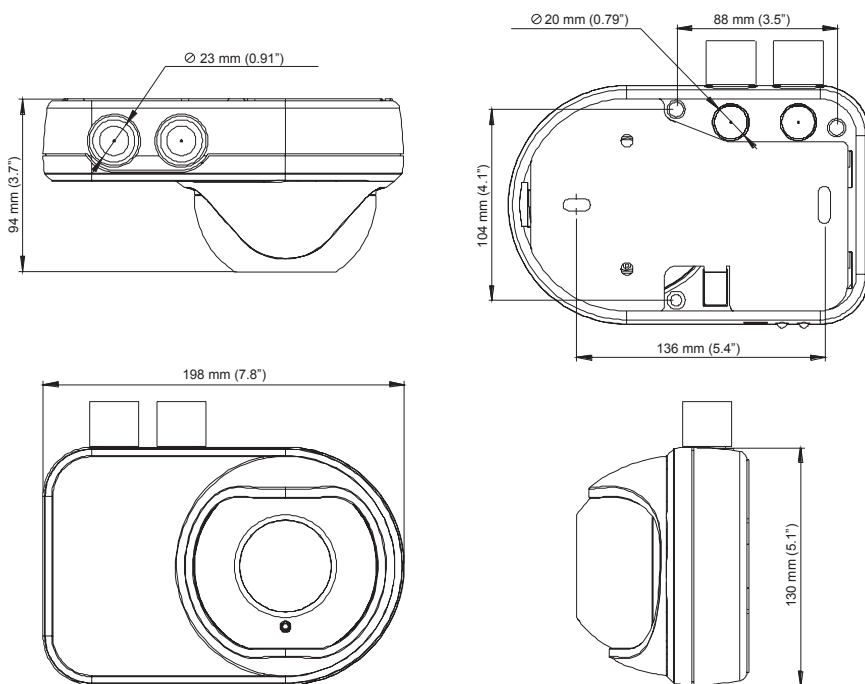

Ordering Information

| | | | |
|-----------|---|--------------|---|
| EF-OSI-10 | Imager - 10° coverage | EF-OSE-SPW | Emitter - Standard Power, Wired Version |
| EF-OSI-45 | Imager - 40° coverage | EF-OSE-HP | Emitter - High Power, Battery Version |
| EF-OSI-90 | Imager - 80° coverage | EF-OSE-HPW | Emitter - High Power, Wired Version |
| EF-OSE-SP | Emitter - Standard Power, Battery Version | EF-OSID-INST | Alignment Tool and Test Filter |